

Exclusive "OR" Circuit

The exclusive "OR" circuit operates as follows: When V-1 is depressed, the signal goes to both V-3 and V-4. The signal at V-4 is blocked. The signal at V-3 actuates the valve and provides an output signal. If V-2 is actuated independently, the same sequence occurs.

If both V-1 and V-2 are actuated, the output at V-4 energizes the bottom pilot which, together with the spring, overrides the opposite pilot of V-3, nullifying both signals, V-3 thus remains off.

Circuit Function

INPUTS	V-1	off	off	on	on
	V-2	off	on	off	on
OUTPUT	V-3	off	on	on	off

Motion Sensing Circuit

V-1 is actuated by rotary or linear cam. Pressure from V-1 goes to a pulse valve (V-2) where it is converted to a uniform pulse each time V-1 is actuated. Each pulse goes through the check valve of V-3 and holds the pilot down on the valve. C-1 is retracted. The pressure holding the pilot of V-3 is constantly trying to exhaust through the adjustable needle valve V-3 and out to atmosphere through the exhaust port of the pulse valve V-2.

When motion stops (or falls below a pre-determined C.P.M.) the pressure on the pilot of V-3 exhausts and the spring shifts the valve, which causes C-1 to extend. The R-341 is shown as Normally-Closed. It can also be used as Normally-Open, a selector, or a diverter.

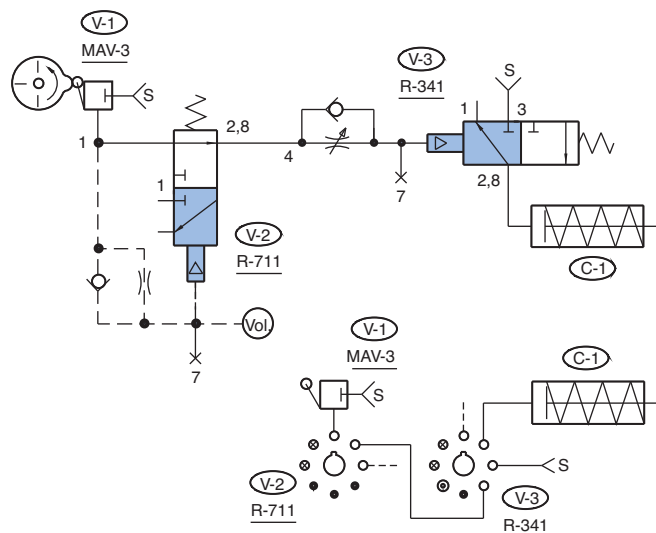

Signal Release Pulse Circuit

This circuit gives a single pulse output of adjustable duration when its input signal is released (exhausted). Upon actuation of the input 3-way valve, V-1, air is supplied to both valve pilots simultaneously so the valve, V-2, remains in the closed position. Upon release of the input signal the pilot on the spring side of the valve is exhausted immediately. This allows the "trapped" air in the volume tank to actuate the valve causing the output to come on. The valve remains actuated until the trapped air bleeds off through the adjustable needle valve.

